

CABOPINO  
MARBELLA

**GOLDEN  
EIGHT**



Building specifications • Memoria de Calidades











# Residence.

## Vivienda.

4

**1.** Floor-to-ceiling solid doors, in MDF with natural oak veneer. With matt black handle. On sliding doors, plain matt black pull handle.

**2.** Hinged cabinet doors in plain solid MDF leaves with natural oak veneer finish. Plain melamine board interior with a linen-textured finish.

**3.** Aluminium window frames lacquered in RAL 7023 colour, with thermal break

**4.** Pressed and rectified porcelain stoneware flooring, 120x120 cm, ivory colour.

**5.** Niessen electrical mechanism, matt black, ZENIT model.

**6.** Underfloor heating throughout the home (not including in storerooms, laundries or garages). Air conditioning with concealed slot diffusers.

**7.** Lighting system composed of 15-watt adjustable lamps in white anodised aluminium finish, with 2700K warm light, for the whole house and 96-watt/m adjustable LED strips, also with 2700K warm light.

**8.** MDF lift wall panelling, veneered with quarter cut oak.

**1.** Puertas de suelo a techo, maciza, de MDF rechapada en madera de roble acabado natural. Con manilla acabado Negro Mate. En puertas corrediza tirador plano color negro mate.

**2.** Puertas de armarios abatibles con hojas enterizas lisas en tablero DM rechapadas en madera de roble acabado natural. Interior de tablero liso de melamina acabado textil lino.

**3.** Ventanas de aluminio lacado color Ral 7023, con rotura de puente térmico.

**4.** Solado gres porcelánico prensado y rectificado en 120x120, color Ivory.

**5.** Mecanismo eléctrico Niessen, modelo ZENIT color Negro Mate.

**6.** Calefacción por suelo radiante en toda la vivienda, (no se incluye en bodegas, lavanderías, ni garajes). Climatización con difusores lineales de ranura oculta.

**7.** Luminarias compuesta por focos de 15 w regulable en acabado aluminio anodizado blanco, con calidez de luz de 2700K para toda la vivienda y tiras de Led 96 w/m regulable, con calidez de luz de 2700K.

**8.** Panelado de muros de ascensor de DM rechapado de roble mallado.



1

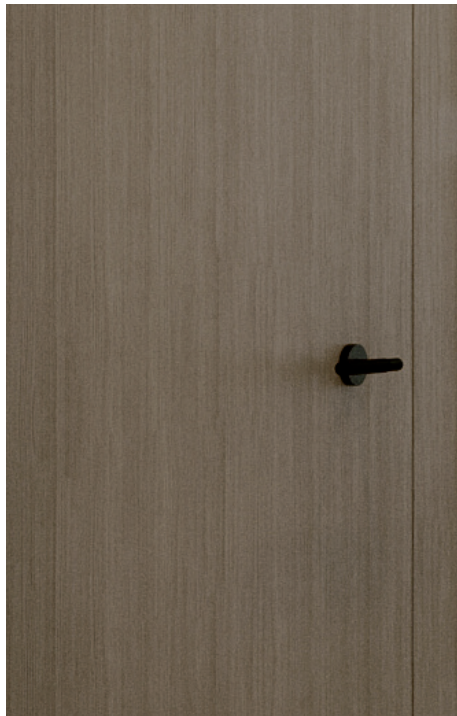

2



3



5



4



5



6

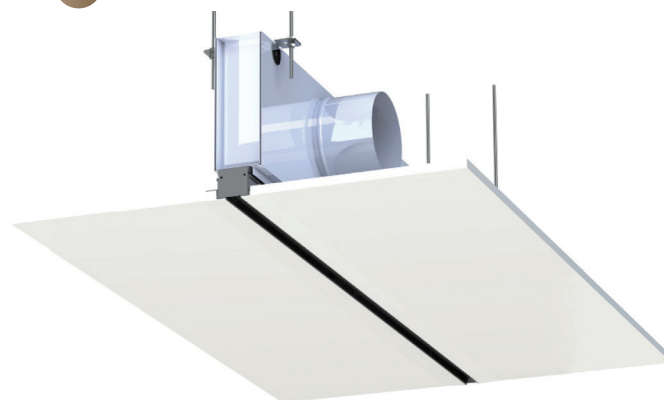



# Bathrooms.

## Baños.

6

**1.** Pressed and rectified full-body porcelain stoneware flooring, 120x120 cm, ivory colour.

**2.** Floor-to-ceiling cladding using large-format porcelain panels with a travertine marble finish.

High-end bathroom accessories in matt black.

**1.** Pavimento de gres porcelánico prensado y rectificado todo masa en 120X120 color Ivory.

**2.** Aplacado de piezas de gran formato de suelo a techo en porcelánico, efecto mármol travertino.

Accesorios de baño de alta gama en negro mate.

1



2





**3.** White wall-hung toilet, NOKEN brand (Porcelanosa Bathroom), Essence C Compact Rimless, with soft-closing seat (Essence C Compact White), ECO concealed cistern with double flush system, matt black double front push button with acoustic protector.

**4.** The main bathrooms will have a white travertine stone countertop, honed open pore finish with resin, with a single built-in sink. Bathroom cabinet with two drawers and front in slatted panel with finger pulls, with a bottom shelf in extra matt oak with a nature colour finish. Planiclear glass with anti-fog system on the back, installed on wall with lacquered waterproof MDF perimeter frame.

**5.** NOKEN (Porcelanosa Bathroom) mixer taps, Rondo built-in model for main bathroom, and countertop, Round, in secondary bathrooms. Built-in wall-mounted shower mixer taps, NOKEN brand (Porcelanosa Bathroom), Rondo model with 3-outlet mixer and arm, spray head and matt black flexible hose.

**6.** Shower tray of 170x100 cm made in place with floor piece, non-slip finish and linear grille in stainless steel, overlaid with floor tiling. Shower screens with fixed floor-to-ceiling glass, recessed door with matt black profile and hinges. PORCELANOSA Optima line.

**3.** Inodoro suspendido en blanco, marca NOKEN (Porcelanosa Bathroom), Essence C Compact Rimless, con asiento soft-closing (Essence C Compact Blanco), Cisterna Empotrada ECO con sistema doble descarga, pulsador frontal doble color negro mate con protector acústico.

**4.** Los baños principales llevarán una encimera de piedra travertino blanco apomazado a poro abierto con resina, con un lavabo de un seno integrado. El mueble de baño con dos cajones y frente de palillera y uñero, con una balda inferior en madera de roble acabado extra mate color nature. Planiclear con sistema antivaho en parte trasera, instalado sobre paramento con marco perimetral de DM hidrófugo lacado.

**5.** Monomandos NOKEN (Porcelanosa Bathroom), modelo Rondo, empotrados para baño principal, y de encimera, Round, en baños secundarios. Monomandos murales empotrados para ducha, marca NOKEN (Porcelanosa Bathroom), modelo Rondo, con mezclador de 3 salidas, y brazo, rociador y flexible color negro mate.

**6.** Plato de ducha 170 x 100 cm elaborado in situ con pieza de solería, acabado antideslizante y rejilla lineal en acero inoxidable, revestida en pieza de solería. Mamparas de ducha con cristal fijo de suelo a techo, puerta rebajada con perfilería y bisagras en negro mate. Línea Optima, PORCELANOSA.

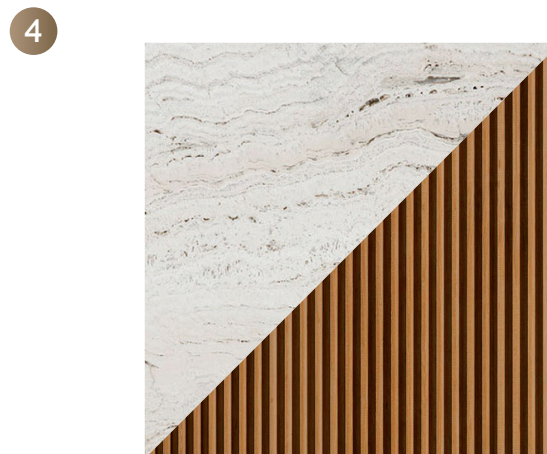



# Communal areas.

## Zonas comunes.

8

1



2



3



4

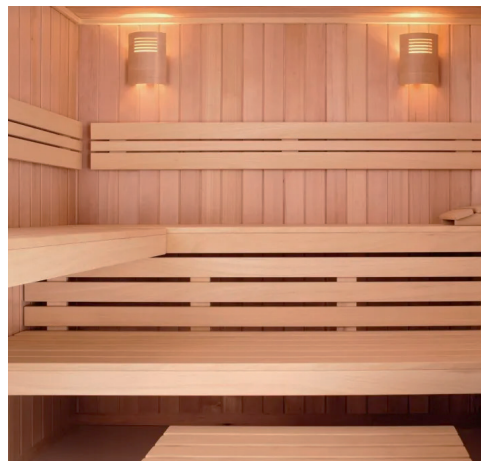

5





**1.** Polished concrete floor in basement roadway and garages. Passageways designed with ornamental white limestone pebble trim.

**2.** Spa flooring in pressed porcelain stoneware flooring, 33.3x100(A) non-slip PORCELANOSA Durango Bone tiles.

**3.** Spa wall tiling in PORCELANOSA Newark Topo 45x120(A).

Pool basin lining in 31.6x31.6x0.4 Porcelanosa Dip Light tiles.

**4.** Natural wood sauna cabin.

**5.** On pedestrian passageways, sections of decorative tiling with large format porcelain stoneware tiles, 120x270(6)(A) PORCELANOSA Fiori di Bosco Nature.

Automatic tilting garage doors, with oak slatting. Sizes A0 4x2.40, B0 4.5x240, C0 5x2.4, D0 4.5x240, A1,B1, C1 and D1 5x2.4.

**1.** Pavimento calle sótano y garajes con hormigón pulido. Pasillos con diseño con piedra decorativa calcárea canto rodado blanco.

**2.** Spa solado de gres porcelánico prensado rectificado, antideslizante Durango Bone 33,3X100(A), PORCELANOSA.

**3.** Alicatado en muros de SPA en NEWARK TOPO 45X120(A), PORCELANOSA.

Revestimiento vaso de piscina en DIP LIGHT 31,6x31,6x0,4, de PORCELANOSA.

**4.** Cabina sauna en madera natural.

**5.** En pasillos peatonales tramos de alicatado decorativo con piezas de gres Porcelánico gran formato FIORI DI BOSCO NAT. 120X270(6)(A) de PORCELANOSA.

Puertas de Garaje automática basculante, con palillera de roble. Tamaños A0 4x2,40, B0 4,5x240, C0 5x2,4, D0 4,5x240, A1,B1, C1 y D1 5x2,4.













# Terraces and solarium.

## Patios y terrazas.

12





1

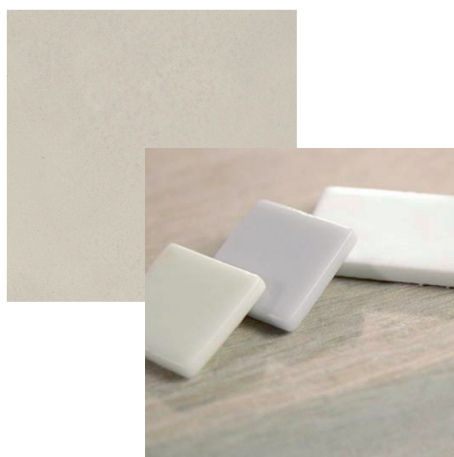

**1.** Pressed and rectified porcelain stoneware flooring, full mass colouring, 120x120 cm, non-slip. Pool basin in matt-finish white tiling, glued to mesh in 33x33 cm panels.

**2.** Laminated glass railings, secured by means of a concealed vertical "U" fixing system in anodised extruded aluminium fixed to reinforced concrete slab/wall.

**3.** Roll-up blinds with concealed drawer, RAL 7023 blades.

**4.** Black outdoor garden spotlight and white wall washer lamp.

**5.** Exterior cladding on South, East and West sides with travertine marble in 120x60 format.

**6.** PORCELANOSA outdoor kitchen with XTONE Bottega Caliza finish, 4-burner Swing Top stainless steel barbecue, stainless steel sink and tap, base unit with XTONE finish, suitable for installation of household appliances.

2



**1.** Pavimento gres porcelánico prensado y rectificado color masa en 120x120 Non Slip. Vaso de piscina con revestimiento gresite en color blanco acabado mate, pegadas sobre malla en paneles de 33x33 cm.

**2.** Barandillas de vidrio laminado, cogido mediante sistema de fijación vertical en "U" oculto de aluminio extrusionado anodizado fijado sobre forjado/murete de hormigón armado.

**3.** Persianas enrollables con cajón oculto lamas Ral 7023.

**4.** Foco exterior de jardín color negro y bañador de pared para muro en color blanco.

**5.** Aplacado exterior en caras Sur, Este y Oeste con mármol travertino en formato 120X60.

**6.** Cocina exterior PORCELANOSA con acabado en XTONE Bottega Caliza, Barbacoa Swing Top de 4 quemadores en acero inoxidable, fregadero y grifo en acero inoxidable, mueble inferior con acabado XTONE, con factibilidad de instalación para electrodomésticos.

3



4



5

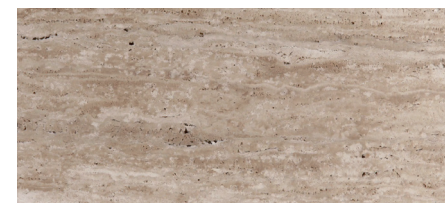



1



2



3

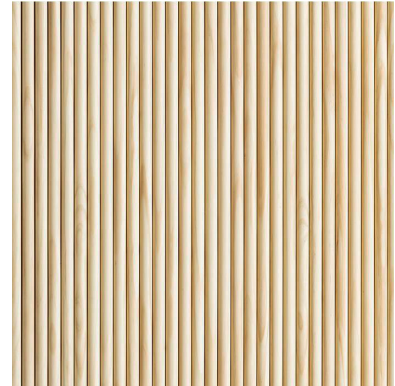

4



5



6



7

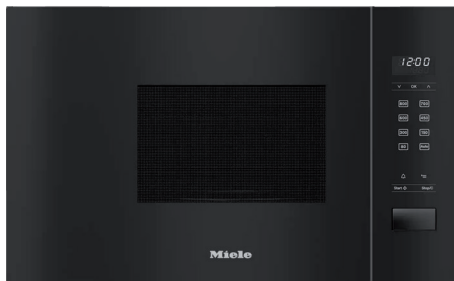

8



9





**Indoor kitchen. Porcelanosa. Features:**

1. Montblanc natural stone countertop, 20mm edge.
2. Furniture finished in oak veneer, including waste bins for modules with 90cm drawer, wooden drawer organiser with pegs, as well as a pull-out unit in corner cabinet.
3. L'Antic Colonial curved island furniture.
4. Induction hob with built-in extraction, Miele KMDA 7476 FL.
5. Multifunction oven, Miele H 7464 BP, with thermal probe and LED lighting.
6. Dishwasher, Miele G 7650 SCVi, automatic dosing.
7. Built-in microwave-oven, Miele M2230SC, operated using sensor controls on the side.
8. Built-in fridge-freezer, Miele KFN 7744 E.
9. Noken brand sink and tap (Porcelanosa Bathroom), anthracite colour.

**Cocina Interior. Porcelanosa. Características:**

1. Encimera Montblanc, piedra natural canto 20mm.
2. Mobiliario acabado en chapa de roble, incluye cubos de residuos para módulos con cajón de 90cms, organizador para cajón en madera y con pivotes para gaveta, además de un extraíble en mueble de rincón.
3. Mueble isla acabado curvo de L'Antic Colonial.
4. Placa inducción Miele con extracción integrada, KMDA 7476 FL.
5. Horno multifunción Miele H 7464 BP, con sonda térmica e iluminación LED.
6. Microondas Miele G 7650 SCVi, auto-dosificación.
7. Horno microondas Miele M 2230 SC empotrada, con manejo a través de los sensores laterales.
8. Combi de Integración Miele, KFN 7744 E.
9. Fregadero y grifo Noken (Porcelanosa Bathroom), en color antracita.





# Laundry.

## Lavandería.

16

### Laundry in basements. Porcelanosa. Features:

1. Krypton 12mm countertop, with built-in sink in the same material.
2. Noken brand tap, matt black.
3. MDF furniture, melamine finish, colour as chosen.
4. Front-loading washing machine, 9 kg, Miele WWR860 WPS PWash2.0&TDosXL&WiFi.
5. Heat pump dryer, 9kg, Miele TWC364WP.
6. Columns with shelves for cleaning utensils, linen, laundry, folding counter.

### Lavandería en Sótanos. Porcelanosa. Características:

1. Encimera Krypton de 12mm, con fregadero integrado en el mismo material.
2. Grifo Marca Noken, negro mate.
3. Mueble MDF, acabado melamina, color según elección.
4. Lavadora carga frontal de 9kg, Miele WWR860WPS PWash2.0&TDosXL&WiFi.
5. Secadora de bomba de calor Miele TWC364WP 9kg.
6. Columnas con estantes para útiles de limpieza, ropa blanca, ropa sucia, mesón de doblado.





1



2



3



4



5



6





# Security and home automation.

## Seguridad y domótica.

18



### **Access control via video intercom.**

(Calls received on the screen and forward to smartphone).

### **IP ColorVU mini dome cameras/High resolution.**

#### **Alarm.**

Alarm. Alarm panel + LIGHTSYS. High-power security system, designed to protect any Grade 2 or Grade 3 installation size or type, allowing up to 512 zones in a single panel. It features:

- High-resolution touch screen keyboard.
- Door and window barriers (infrared mini barrier).
- Motion sensor.
- Smoke detectors.
- Panic button.
- Magnetic contactors.

### **Control de acceso mediante vídeo portero.**

(Llamadas recibidas en pantalla y desvío a smartphone).

### **Cámaras IP ColorVU y minidomos / Alta resolución.**

#### **Alarma.**

Alarma. Panel de alarma + LIGHTSYS. Sistema de seguridad de alta potencia, diseñado para proteger cualquier tamaño o tipo de instalación de Grado 2 o Grado 3, lo que permite hasta 512 zonas en un solo panel. Cuenta con:

- Teclado con pantalla táctil en alta resolución.
- Barrera puertas y ventanas (Mini barrera de infrarrojos).
- Sensor de movimiento.
- Detectores de humo.
- Pulsador atraco.
- Contactores magnéticos.



1



**1. Zennio home automation.** All the homes are equipped with a home automation system that lets you control your property from fixed devices when inside, and from an app that can be used anywhere with an internet connection. The system relies on the universal KNX communication standard, which can be used to control various programmed functions.

The different features included in this promotion are explained below: 7" touchscreen located on ground floor entrances and first floor to control the home, including remote control via app with access to the video intercom at the main entrance to the development. 3.5" touchscreen to control the master bedroom and basement. Flat 55 screens to control the air-conditioning in secondary bedrooms. There is a proximity and brightness sensor with adaptive backlighting in the touch areas.

**2. Heating and cooling.** Integrated AIRZONE system. Temperature regulation from thermostats and screens.

**3. Lighting.** Option to control the lighting and create scenes for different settings in the living room, master bedroom and basement.

2



**1. Domótica Zennio.** Todas las viviendas están dotadas de un sistema de domótica que le permite controlar su propiedad desde dispositivos fijos, en su interior, y desde una App que puede ser utilizada en cualquier lugar con conexión a internet. La base del sistema es el estándar universal de comunicación KNX, que permite controlar distintas funciones programadas.

A continuación, se explican las diferentes funcionalidades incluidas en esta promoción: Pantalla táctil 7" ubicada en accesos en planta baja y planta primera para el control de la vivienda, incluyendo control remoto mediante App, con conexión al videoportero de la entrada principal a la urbanización. Pantalla táctil 3,5" para el control de Master Bedroom y planta sótano. Pantallas Flat 55 para control de la climatización en dormitorios secundarios. Se dispone de sensor de proximidad y luminosidad con retro iluminación adaptativa en las áreas de pulsación.

**2. Climatización.** Integración sistema AIRZONE. Regulación de temperatura desde los termostatos y pantallas.

**3. Iluminación.** Posibilidad de controlar la iluminación y crear escenas para diferentes ambientes en salón, dormitorio principal y sótano.



Promoted by:  
Promovido por:



+34 679 172 496  
[goldeneight.es](http://goldeneight.es)